



## September 2022 NRL22 Official Course of Fire

**PractiScore Template:** Here is the link for the PractiScore template for this month's COF. This template has all the stages already built for you if you don't want to create them yourself. All you need to do is follow the instructions to the letter otherwise you risk your match results being overwritten. [PractiScore Template](#)

**DFAT Range Card:** The DST Precision DFAT allows you to use the rifle and optic to dryfire practice in a very small area such as your garage, living room, or even bedroom. With this adapter most scopes focus in the 11-15 feet range. You can find this month's COF range card here. [DFAT Range Practice Range Card](#)

**COF Designer:** Victor Vuong out of Renton, Washington at Short Range Precision Rimfire. Thank you Victor for coming up with a really fun but challenging course of fire.

If you have questions about the COF please email Dominic at [Dom@NRL22.org](mailto:Dom@NRL22.org)

**Range requirements:** This month's COF will require a 3x Tires, Ladder, 3x Cinder Blocks, Rooftop, Sawhorse, 55-gal barrel, 5-gal bucket, 2-gal bucket, Chair, a stopwatch that can time down to a tenth of a second, and the NRL22 standard target package. Left over targets: 1x 1", 2x 2", 1x 2.5", 1x 4", 1x 6"

**Scoring submissions:** In accordance with the 2022 NRL22 rules, Match Directors are required to submit scores within 7 days of their match concluding. Download the NRL22 Scores sheet from the downloads section on [NRL22.org/downloads](http://NRL22.org/downloads), fill out the results, and submit scores through the [NRL22.org](http://NRL22.org) by clicking [here](#), followed by payment for the match admin fee. Deadline for submissions is **October 5th, 2022**. Keep in mind that only NRL22 members are eligible for prizes and while we have a 7-day grace period for membership, if the prizes are already distributed, it is the competitor's loss. The live Facebook show for prizes will happen on **October 12th, 2022**.



## September 2022 NRL22 Official Course of Fire

Here is the running list of approved out-of-production rifles that will remain in Base division. These rifles must be in their original factory configuration to be eligible for Base division. The only modifications to those rifles are the ones listed in the NRL22 Rules Section 5. B. The burden of providing solid evidence for inclusion into Base division rests squarely on the shooter, and the MD makes the final call on which class the shooter's rifle gets classified in.

- CZ 452 (all models)
- CZ 455 (all models)
- Savage (all models, except Savage Anschutz)
- Ruger (all models)
- Marlin/Glenfield
  - Levermatic
  - Model 20
  - Model 780
  - Model 39A (variants & predecessors)
- Mossberg (all models)
- Winchester
  - Model 69 & variants
  - Model 131 & 141 (including SR variants)
- Coeey
  - 64 (predecessor to Savage 64)
  
- Example #1: The CZ 452 American had an MSRP of \$409.00 in 2007. Inflation adjustment puts that MSRP at \$618.65 in 2021. This is clearly in line with many other "base class" rifles including several versions of the CZ 457.
- Example #2: The CZ 455 Varmint Precision Trainer had an MSRP of \$967 in 2018. Inflation adjustment puts that MSRP at \$1056.67 in 2021. Unless the competitor is electing to shoot with iron sights, it would be practically impossible for this model to stay under the applicable \$\$\$ threshold.
- Example #3. The Winchester Model 52 Sporter had an MSRP of just \$88.50 in 1934. However, 87 years of compound inflation really adds up. Inflation adjustment puts that MSRP at \$1158.20 in 2021. The Model 52 will be a ton of fun to shoot, ...in Open class.

Inflation/compound interest calculator can be found at <https://www.investor.gov/financial-tools-calculators/calculators/compound-interest-calculator>

Use a fixed 3.0% rate, nothing for variance range, compound annually

# Never Forget

Time: 120 Sec

Round Count: 12

Option 1 - 50 yds: 1.5" on a single hanger  
70 yds: 2" on a single hanger  
80 yds: 2.5" on a single hanger  
100 yds: 3" on a single hanger

## Ranges and Targets:

Option 2 - 50 yds: 1.5"  
70 yds: 2"  
80 yds: 2.5"  
100 yds: 3"

**Stressor: All positions are fired from the support side.**

**Restrictions:** None

**Points:** 10 points per impact, 120 points possible

**Start Position:** Standing, rifle and all gear in hand, mag in, action open

**Description:** On the start signal, take a position on the ladder and engage the targets in the following manner with 1 round each (hit or miss, move on):

- Any ladder rung that is not touching the tire, near to far
- Different ladder rung, far to near
- Different ladder rung, near to far

**Note:** Elevation and Windage turrets cannot be changed. The only change allowed is parallax and magnification.

**OG/Adaptive Recommendation:** Same starting position. Bottom of the ladder can be on a 55-gal barrel and the top of the ladder will remain on the tires. Shooter may use a chair or stool. Shooter will alternate between 2 rungs after every 4<sup>th</sup> shot.

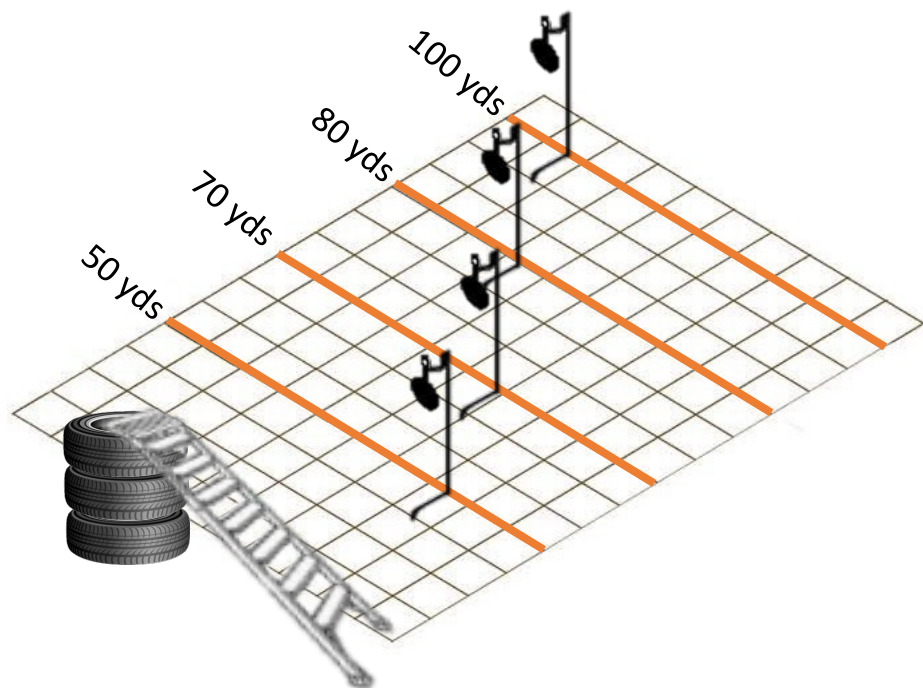

# Rebuilding Brick By Brick

Time: 120 Sec

Round Count: 10

Option 1 – 35 yds: 1", 0.75", 0.5", 0.25" on a KYL rack  
100 yds: 3" on a double hanger

## Ranges and Targets:

Option 2 – 105 yds: 4", 3", 2.5", 2"  
150 yds: 6"

**Restrictions:** None

**Points:** 10 points per impact, 100 points possible

**Start Position:** Standing, rifle and all gear in hand, mag in, action open

**Description:** On the start signal, the shooter will engage the targets with 1 shot, hit or miss move on, in the following manner and order:

- Double blocks – Far Target
- Single block – 1"
- Double blocks – Far Target
- Single block –  $\frac{3}{4}$ "
- Double blocks – Far Target
- Single block –  $\frac{1}{2}$ "
- Double blocks – Far Target
- Single block –  $\frac{1}{4}$ "
- Double blocks – Far Target
- Single block –  $\frac{1}{4}$ "

**OG/Adaptive Recommendation:** Same starting position. The cinder blocks can be on an elevated position.

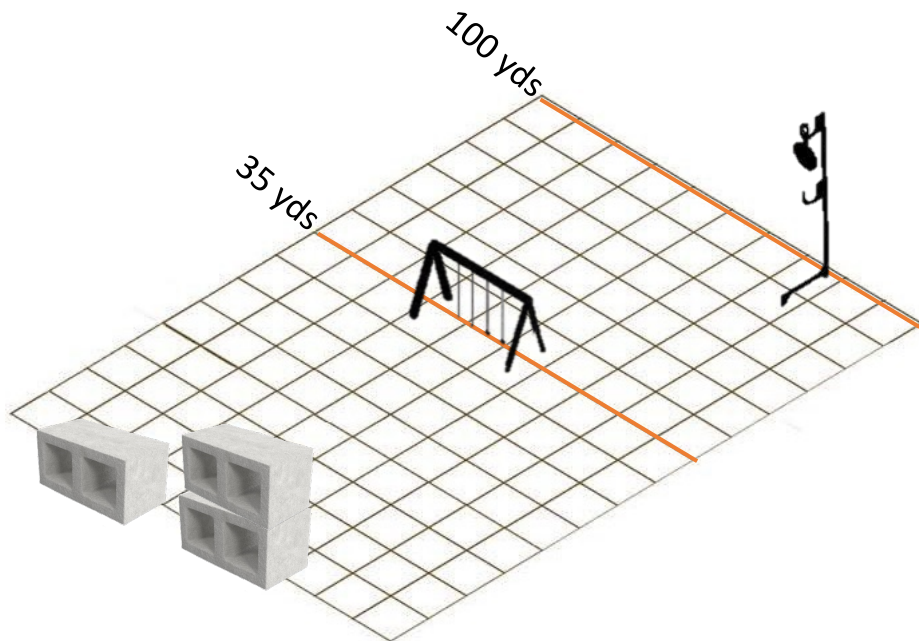

# Lest We Forget The Fallen II

Time: 120 Sec

Round Count: 10

Option 1 – 30 yds: 1" on a double hanger  
75 yds: 2.5" on a double hanger

## Ranges and Targets:

Option 2 – 30 yds: 1"  
75 yds: 2.5"

**Stressor: Reverse rooftop**

**Restrictions:** The shooter's entire body and equipment/rifle must be on the rooftop.

**Points:** 10 points per impact, 100 points possible

**Start Position:** Standing, rifle and all gear in hand, mag in, action open

**Description:** On the start signal, the shooter will ascend the rooftop and engage each target with 2 shots near, then 2 shots far, and repeat sequence till out of time or ammo.

Note: For safety, the rifle may be handed to the shooter when ascending and descending.

The rooftop is sideways and facing to the side with the peak on the right.

**OG/Adaptive Recommendation:** Same starting position and shooting order; however, all targets will be engaged from the peak of the rooftop from the shooter's support side. A stool or chair may be used to sit on.

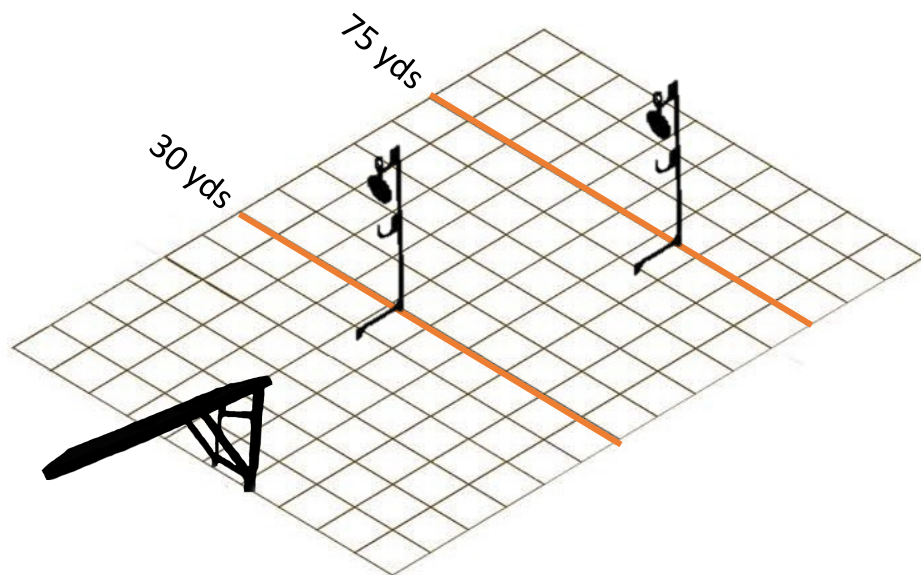

# Through The Rubble

Time: 120 Sec

Round Count: 10

Option 1 – 100 yds: 3” on a double hanger

## Ranges and Targets:

Option 2 – 175 yds: 8”

**Restrictions:** No part of the equipment/rifle may touch the ground

**Points:** 10 points per impact, 100 points possible

**Start Position:** Standing, rifle and all gear in hand, mag in, action open

**Description:** On the start signal, engage the target with 2 shots in the following prop order:

- Top of the sawhorse
- 55-gallon barrel
- Seat of the chair
- 2-gallon bucket
- 5-gallon bucket

**Note:** All props are scrunched together and positioned as pictured.

**OG/Adaptive Recommendation:** Same starting position. 55-gal barrel will be upright. Shooter will alternate between 55-gal barrel and sawhorse after every 2nd shot.

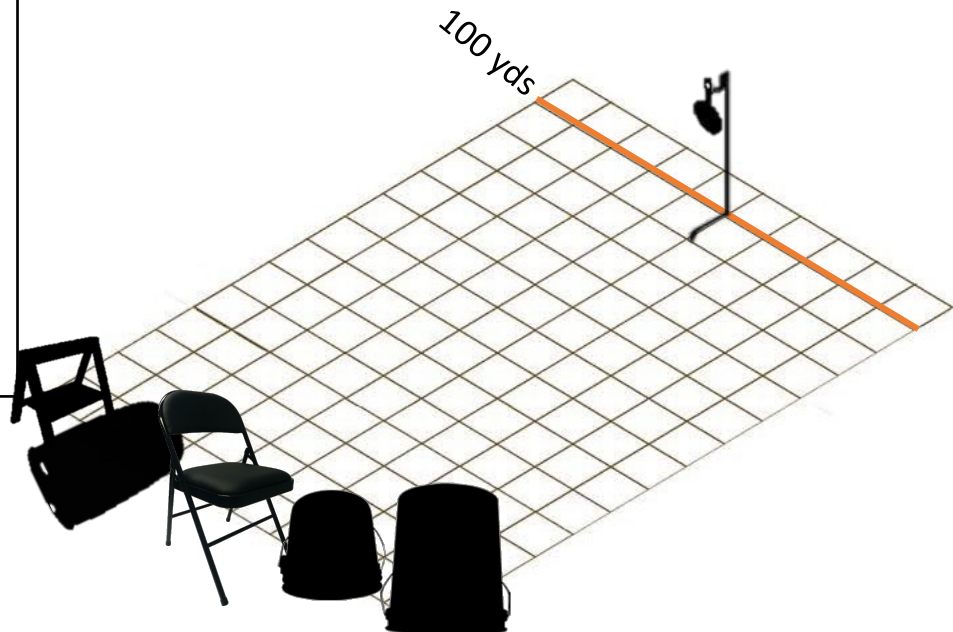

# 9-1-1

Time: 120 Sec

Round Count: 11

Option 1 – 85 yds: 1.5" on a double hanger  
85 yds: 1.5" & 5" on a double hanger

## Ranges and Targets:

Option 2 200 yds: 6"  
200 yds: 6" & 12"

**Restrictions:** None

**Points:** 10 pts per impact plus 0.1 bonus points per second remaining.  
**For the PractiScore NRL22 template enter the total time elapsed in seconds.**

**Start Position:** Standing, rifle and all gear in hand, mag in, action open

**Description:** On the start signal, take a supported prone position, and engage the small target with 1 round alternating left then right until 9 rounds have been fired.

The shooter will then take an unsupported seated position and engage the large target with 1 shot.

The shooter will then perform a **mandatory reload** and engage the large target with 1 shot from the unsupported seated position again.

**OG/Adaptive Recommendation:** Shooter may start in position or shoot from a 55-gal barrel. When shooting the seated position, the shooter may use a stool or chair.

