



August 2022 NRL22 Official Course of Fire

PractiScore Template: Here is the link for the PractiScore template for this month's COF. This template has all the stages already built for you if you don't want to create them yourself. All you need to do is follow the instructions to the letter otherwise you risk your match results being overwritten. [PractiScore Template](#)

DFAT Range Card: The DST Precision DFAT allows you to use the rifle and optic to dryfire practice in a very small area such as your garage, living room, or even bedroom. With this adapter most scopes focus in the 11-15 feet range. You can find this month's COF range card here. [DFAT Range Practice Range Card](#)

COF Designer: Our friends from down under designed this beauty. Thank you, Corey McLennah from NRL22 Australia. Corey is currently a competitor in Australia and works closely with the NRL22 Australia organization.

If you have questions about the COF please email Dominic at Dom@NRL22.org

Range requirements: This month's COF will require a 5-gallon bucket, tank trap, ladder, 2x tires, a stopwatch that can time down to a tenth of a second, and the NRL22 standard target package. Left over targets: 1x 1", 2x 1.5", 2x 2.5", 1x 3", 1x 4", 1x 5", and 1x 6".

Scoring submissions: In accordance with the 2022 NRL22 rules, Match Directors are required to submit scores within 7 days of their match concluding. Download the NRL22 Scores sheet from the downloads section on NRL22.org/downloads, fill out the results, and submit scores through the NRL22.org by clicking [here](#), followed by payment for the match admin fee. Deadline for submissions is **September 7th, 2022**. Keep in mind that only NRL22 members are eligible for prizes and while we have a 7-day grace period for membership, if the prizes are already distributed, it is the competitor's loss. The live Facebook show for prizes will happen on **September 14th, 2022**.

August 2022 NRL22 Official Course of Fire

Here is the running list of approved out-of-production rifles that will remain in base class. These rifles must be in their original factory configuration to be eligible for base class. The only modifications to those rifles are the ones listed in the NRL22 Rules Section 5. B. The burden of providing solid evidence for inclusion into base class rests squarely on the shooter, and the MD makes the final call on which class the shooter's rifle gets classified in.

- CZ 452 (all models)
- CZ 455 (all models)
- Savage (all models, except Savage Anschutz)
- Ruger (all models)
- Marlin/Glenfield
 - Levermatic
 - Model 20
 - Model 60 (aka Glenfield 60) & historical variants
 - Model 65 (aka Glenfield 65) & historical variants
 - Model 780
 - Model 39A (variants & predecessors)
- Mossberg (all models)
- Winchester
 - Model 69 & variants
 - Model 131 & 141 (including SR variants)
- Cooney
 - 60
 - 64 (predecessor to Savage 64)

- Example #1: The CZ 452 American had an MSRP of \$409.00 in 2007. Inflation adjustment puts that MSRP at \$618.65 in 2021. This is clearly in line with many other “base class” rifles including several versions of the CZ 457.
- Example #2: The CZ 455 Varmint Precision Trainer had an MSRP of \$967 in 2018. Inflation adjustment puts that MSRP at \$1056.67 in 2021. Unless the competitor is electing to shoot with iron sights, it would be practically impossible for this model to stay under the applicable \$\$\$ threshold.
- Example #3. The Winchester Model 52 Sporter had an MSRP of just \$88.50 in 1934. However, 87 years of compound inflation really adds up. Inflation adjustment puts that MSRP at \$1158.20 in 2021. The Model 52 will be a ton of fun to shoot, ...in Open class.

Inflation/compound interest calculator can be found at <https://www.investor.gov/financial-tools-calculators/calculators/compound-interest-calculator>

Use a fixed 3.0% rate, nothing for variance range, compound annually

Thunder Down Under

Time: 120 Sec

Round Count: 10

Ranges and Targets:

Option 1 - 65 yds: 2" on a single hanger
85 yds: 3" on a single hanger

Option 2 - 65 yds: 2" on a single hanger
85 yds: 3" on a single hanger

Stressor: 90 sec per time

Points: 10 points per impact, 100 points possible

Start Position: Standing, rifle and all gear in hand, mag in, action open

Description: On the start signal, the shooter will engage the targets in the following manner and order:

1. Any leg – far target w/ 3 shots
2. Any tip – near target w/ 2 shots
3. Different leg – far target w/ 3 shots
4. Different tip – near target w/ 2 shots

Note: When shooting from the legs (below the center) no rear support equipment may be used to support the rifle.

The tip is the furthest portion on the tank trap above the center.

OG/Adaptive Recommendation: Same starting position. The shooter can use any tip or the center of the tank trap but must change to a different position after the prescribed number of shots.

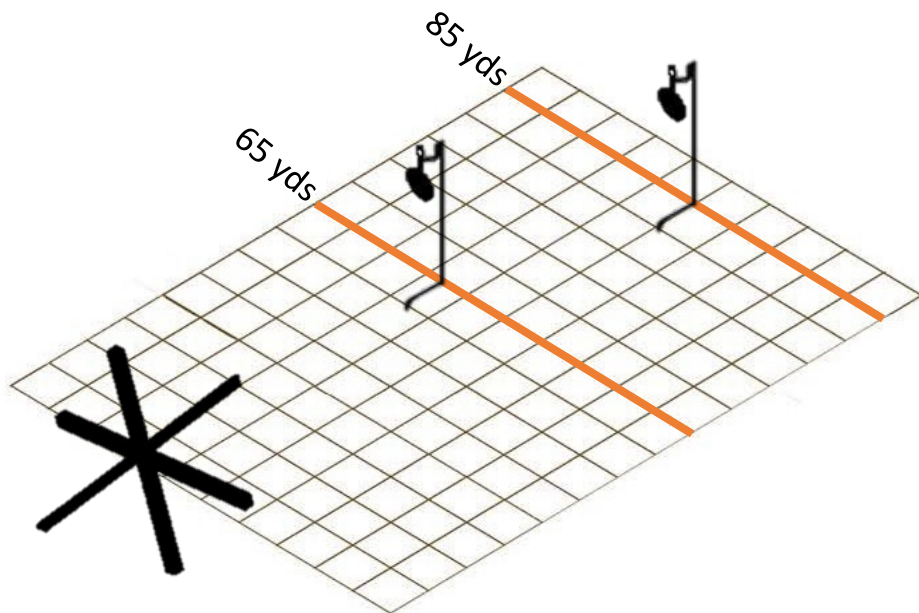

There's A Hole In My Bucket

Time: 120 Sec

Round Count: 10

Option 1 – 45 yds: 1" on a double hanger
60 yds: 1.5" on a double hanger
95 yds: 2" on a double hanger

Ranges and Targets:

Option 2 – 68 yds: 2"
90 yds: 3"
143 yds: 4"

Points: 10 points per impact, 100 points possible

Start Position: Standing, rifle and all gear in hand, mag in, action open

Description: On the start signal, the shooter will engage the targets with 1 shot, hit or miss, in the following order and manner:

1. Prone (left of bucket) – near to far
2. On the bucket rim – middle then near
3. Prone (right of bucket) - near to far but support side
4. On the bucket rim – middle then near but support side.

Note: When shooting from the bucket a bipod cannot be deployed where the feet are on the ground or on the bottom of the bucket.

Support side means, support eye shoulder, and hand.

OG/Adaptive Recommendation: Same starting position. The bucket can be placed on an elevated position. Prone shots can be taken from a bench or a 55-gal barrel.

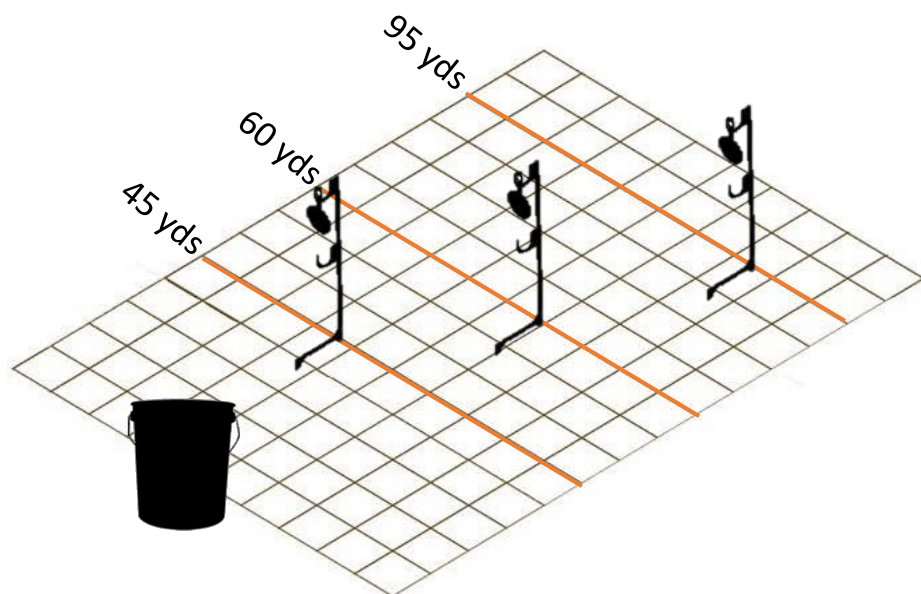

Top Gun – Never Leave Your Wingman

Time: 120 Sec

Round Count: 12

Ranges and Targets:

Option 1 – 42 yds: KYL rack with 1", 0.75", 0.5", 0.25"
69 yds: 2" on a single hanger

Option 2 – 42 yds: KYL rack with 1", 0.75", 0.5", 0.25"
69 yds: 2" on a single hanger

Stressor: Shooter must load their spare mag on the clock

Points: 10 points per impact, 120 points possible

Start Position: Standing, rifle and all gear in hand, mag in, action open

Description: On the start signal, the shooter will assume a prone supported position with only 2 rounds in their mag and engage the 1" KYL target with 2 shots.

The shooter will then retrieve their spare mag behind the firing line (~10 feet away) and engage the targets in the following order and manner:

1. Far target w/ 1 shot
2. KYL from large to small w/ 1 shot each
3. Far target w/ 1 shot
4. KYL from large to small w/ 1 shot each

OG/Adaptive Recommendation: Starting in position and shot in the same order. When retrieving their spare mag, the shooter can have it next to their rifle or the shooter may shoot off a 55-gal barrel and shoot the stage as described.

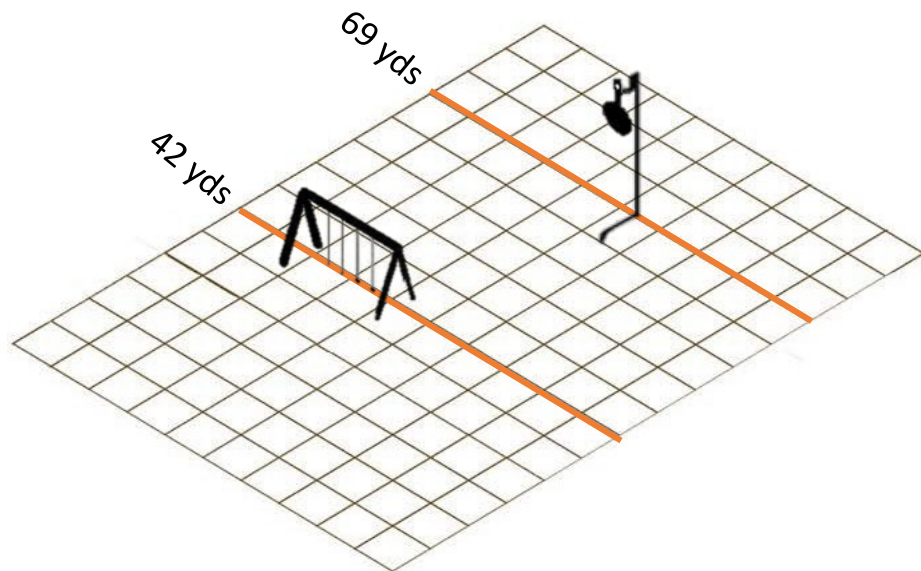

Rung Out

Time: 120 Sec

Round Count: 10

Ranges and Targets:

Option 1 – 100 yds: 3" on a single hanger

Option 2 – 150 yds: 6"

Points: 10 points per impact, 100 points possible

Start Position: Standing, rifle and all gear in hand, mag in, action open

Description: On the start signal, the shooter will engage the target with 1 shot from each ladder rung, hit or miss move on.

The shooter will start from the highest ladder rung they can safely reach and work their way down, up, and back down again without skipping for 10 shots or time expires.

OG/Adaptive Recommendation: Same starting position. The shooter will use the top 2 rungs they can reach. Shot in the same manner.

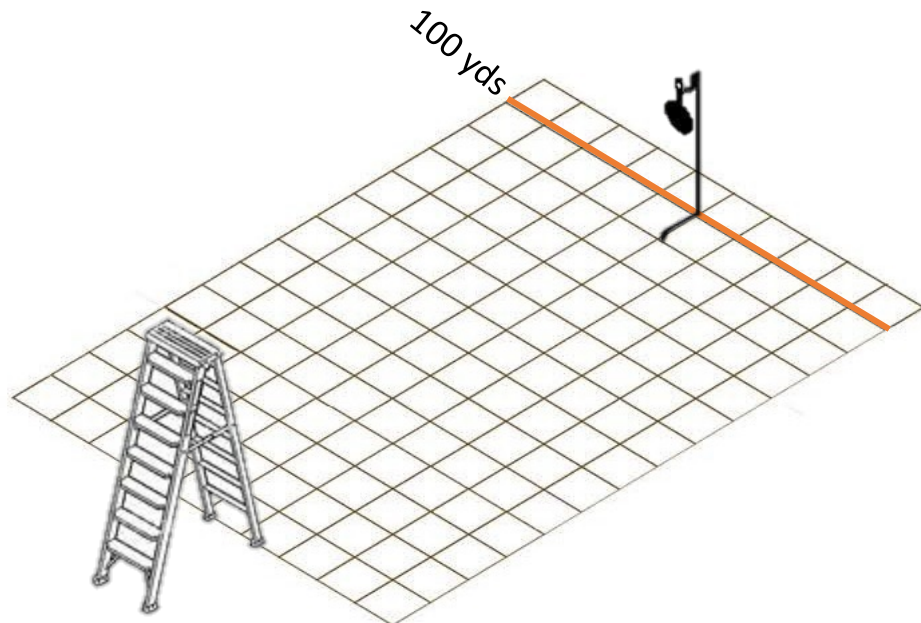

Too Tired For This Shoot

Time: 120 Sec

Round Count: 10

Option 1 – 85 yds: 2.5” on a double hanger

Ranges and Targets: Option 2 – 85 yds: 2.5” on a double hanger

Stressor: 1 shot from each position.

Positions can't be repeated back-to-back

Points: 10 pts per impact plus 0.1 bonus points per second remaining.
For the PractiScore NRL22 template enter the total time elapsed in seconds.

Start Position: Standing, rifle and all gear in hand, mag in, action open

Description: On the start signal, the shooter will engage the target in the following order and manner:

1. Upright tire – 2 shots
2. Flat tire on the right – 3 shots
3. Upright tire – 3 shots
4. Flat tire on the left – 2 shots

The shooter will yell “done” to stop the timer.

OG/Adaptive Recommendation: No change other than the tires can be placed on an elevated position.

