

Bay 1 - Purple Flags, firing line mid bay.
Best 4 of 5 runs.

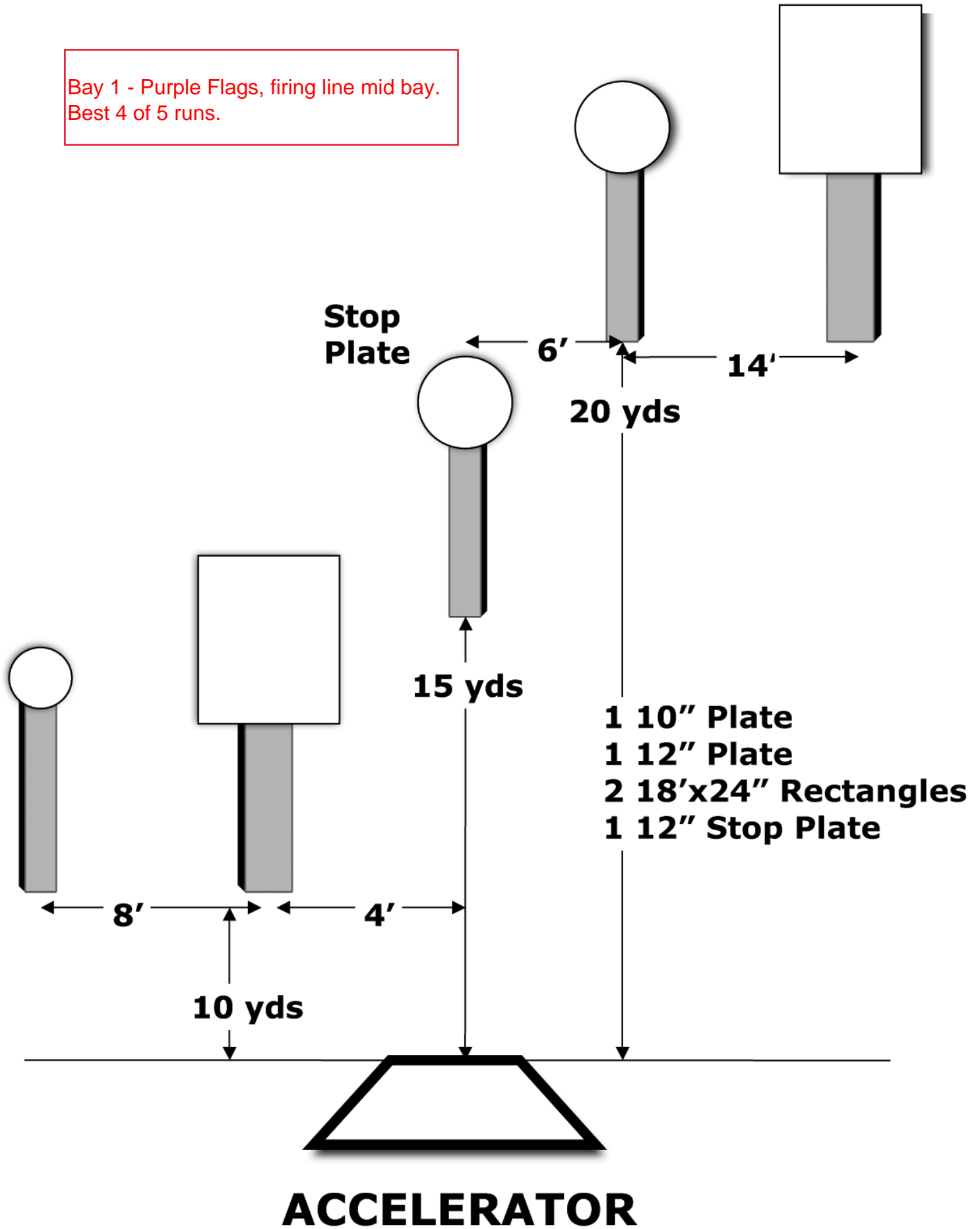

Bay 2 - orange flags
Best 4 of 5 runs

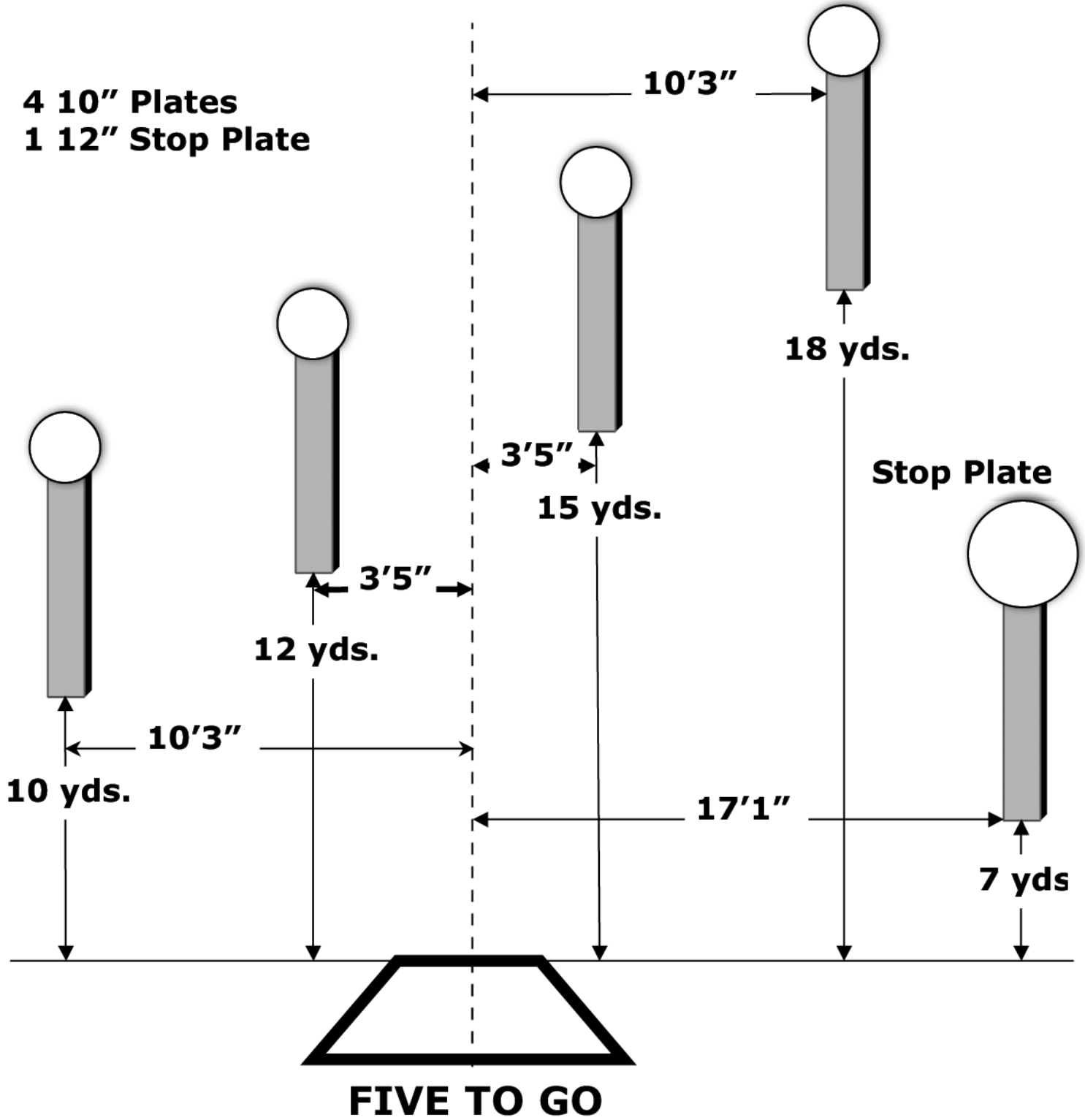

Bay 2 -- Green Flags

This stage requires movement during the run
Start on weak side, shoot weak side 20 and 35 yd, then move to the center, shoot strong side 20, 35, and stop. Only two boxes to be used by shooter. Best 3 of 4 runs.

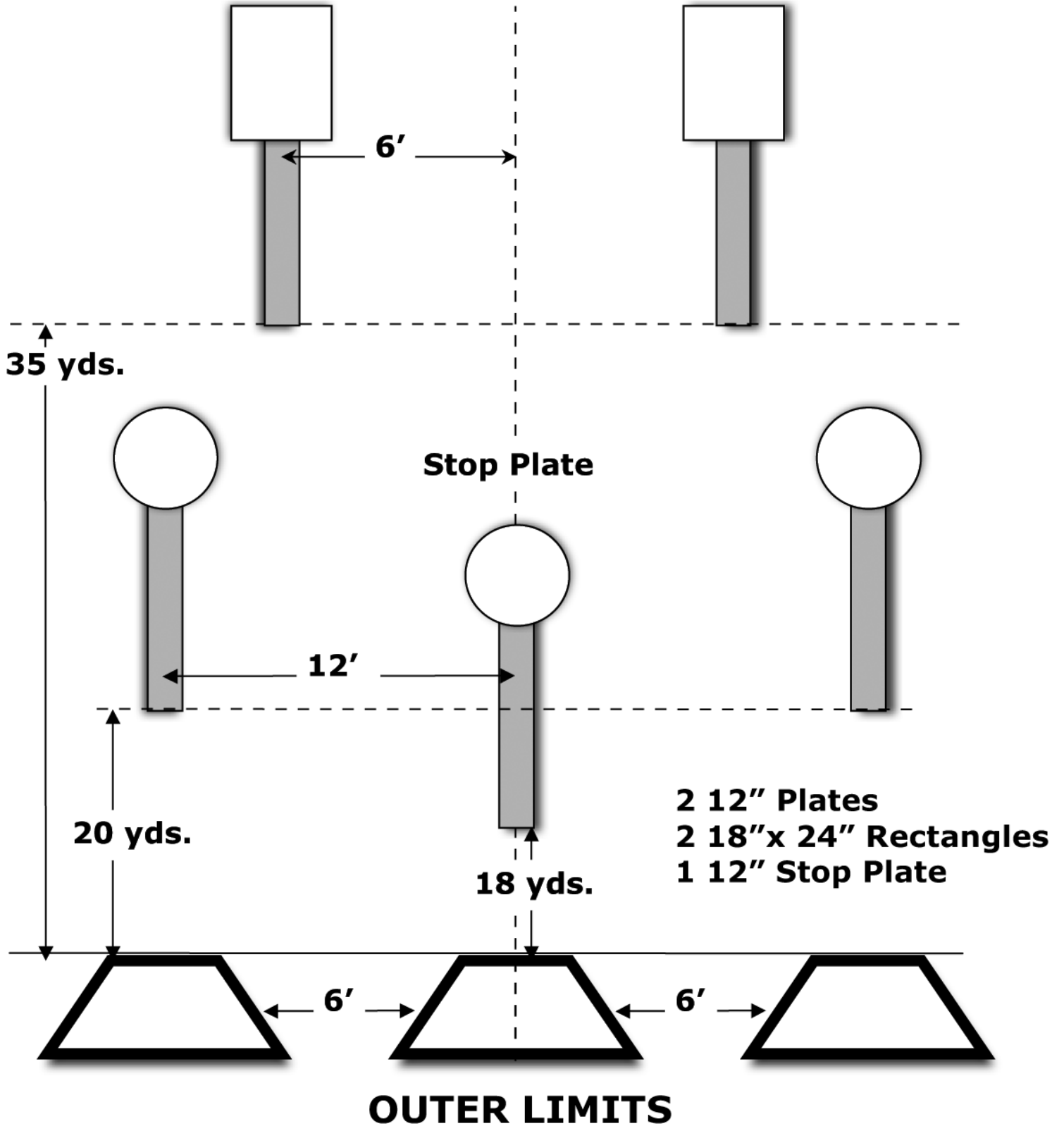

Bay 6 -- Old Pink/Purple Flags
Best 4 of 5 runs.

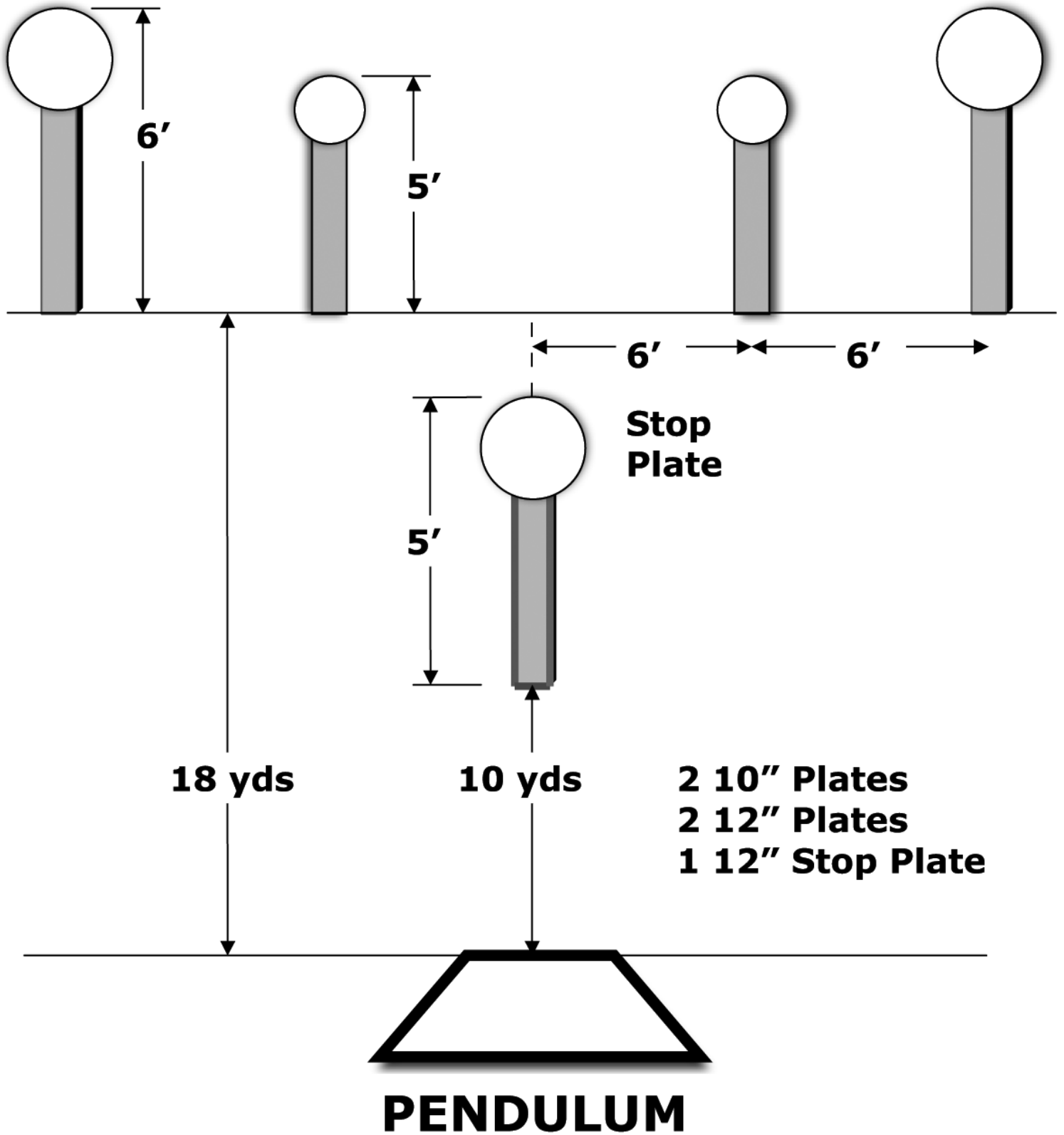

Bay 5 -- Blue Flags
Best 4 of 5 runs.

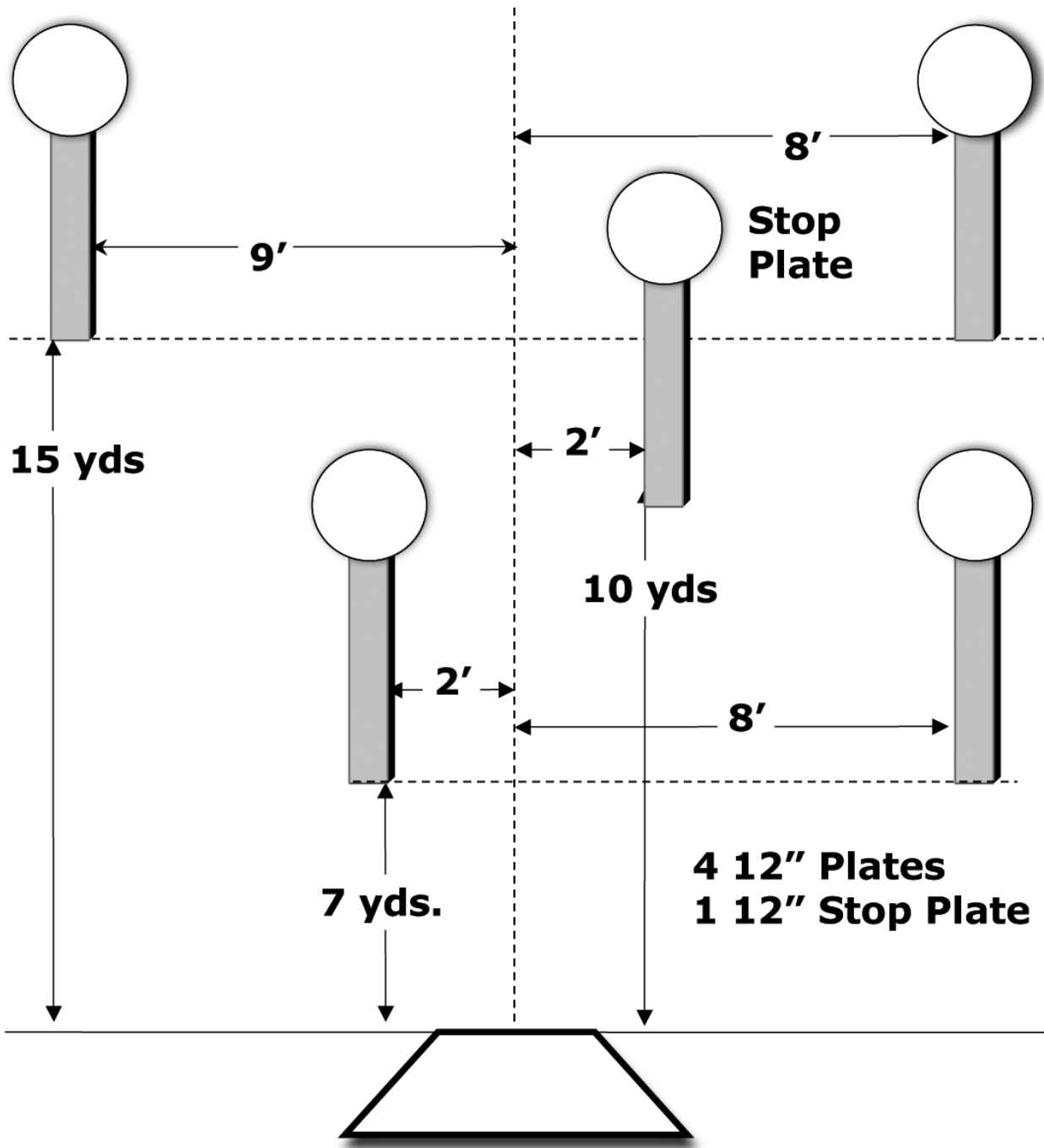

ROUNABOUT

Bay 1 -- Purple/Green Flags
 Shoot two runs from weak side
 Shoot two runs from strong side
 Shooters choice for 5th run
 There is no movement during a run.
 Best 4 of 5 runs.

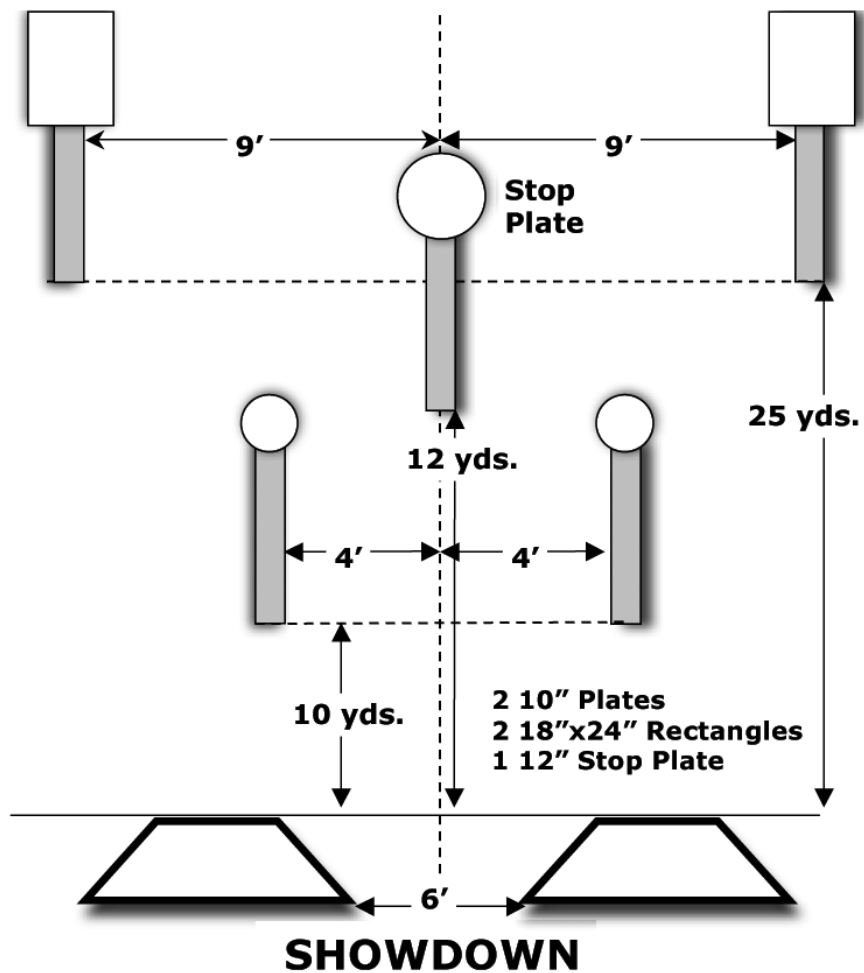

Bay 1 -- Blue Flags
Best 4 of 5 runs.

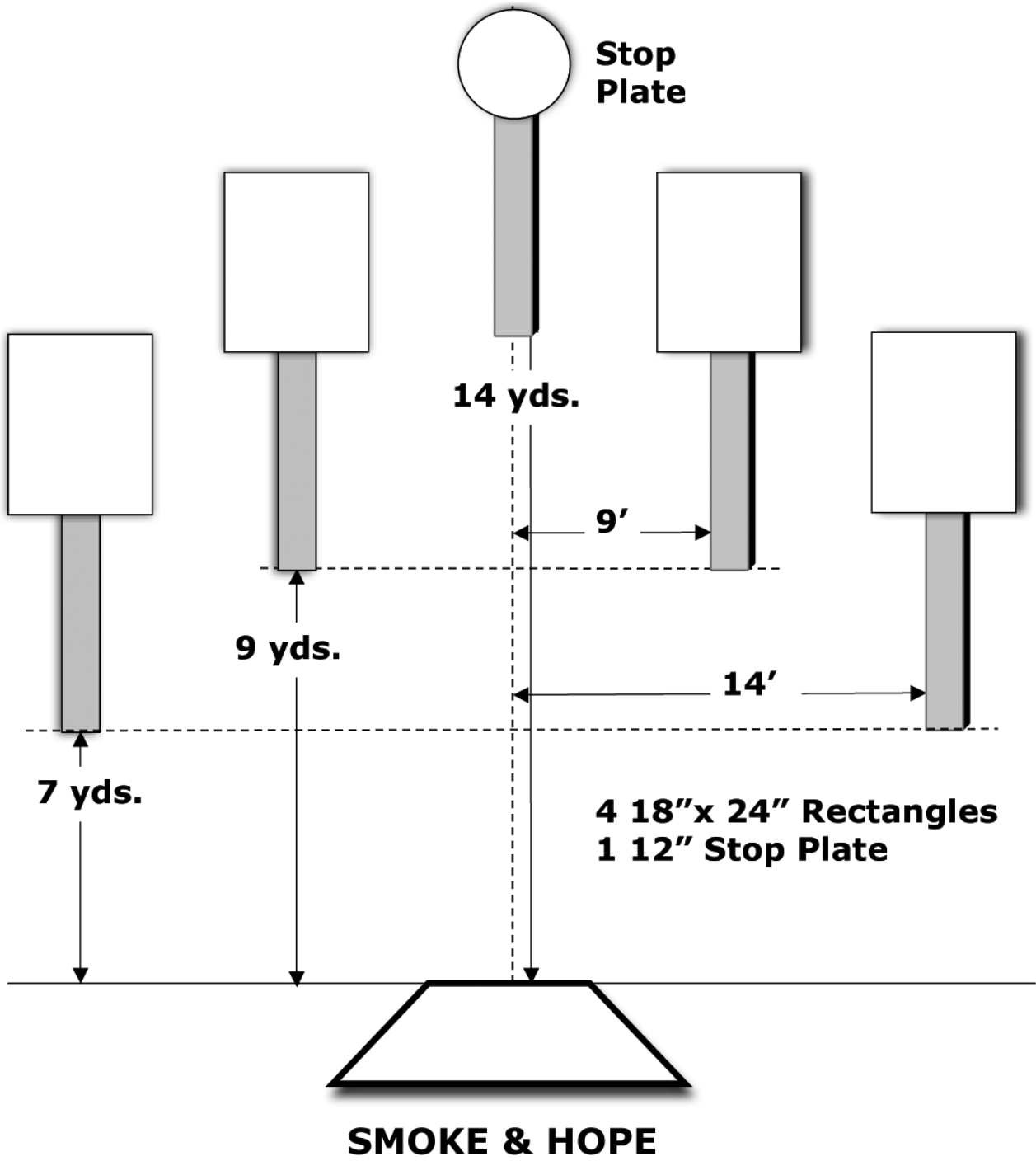

Bay 2 -- Old Orange/Purple flags
Best 4 of 5 runs.

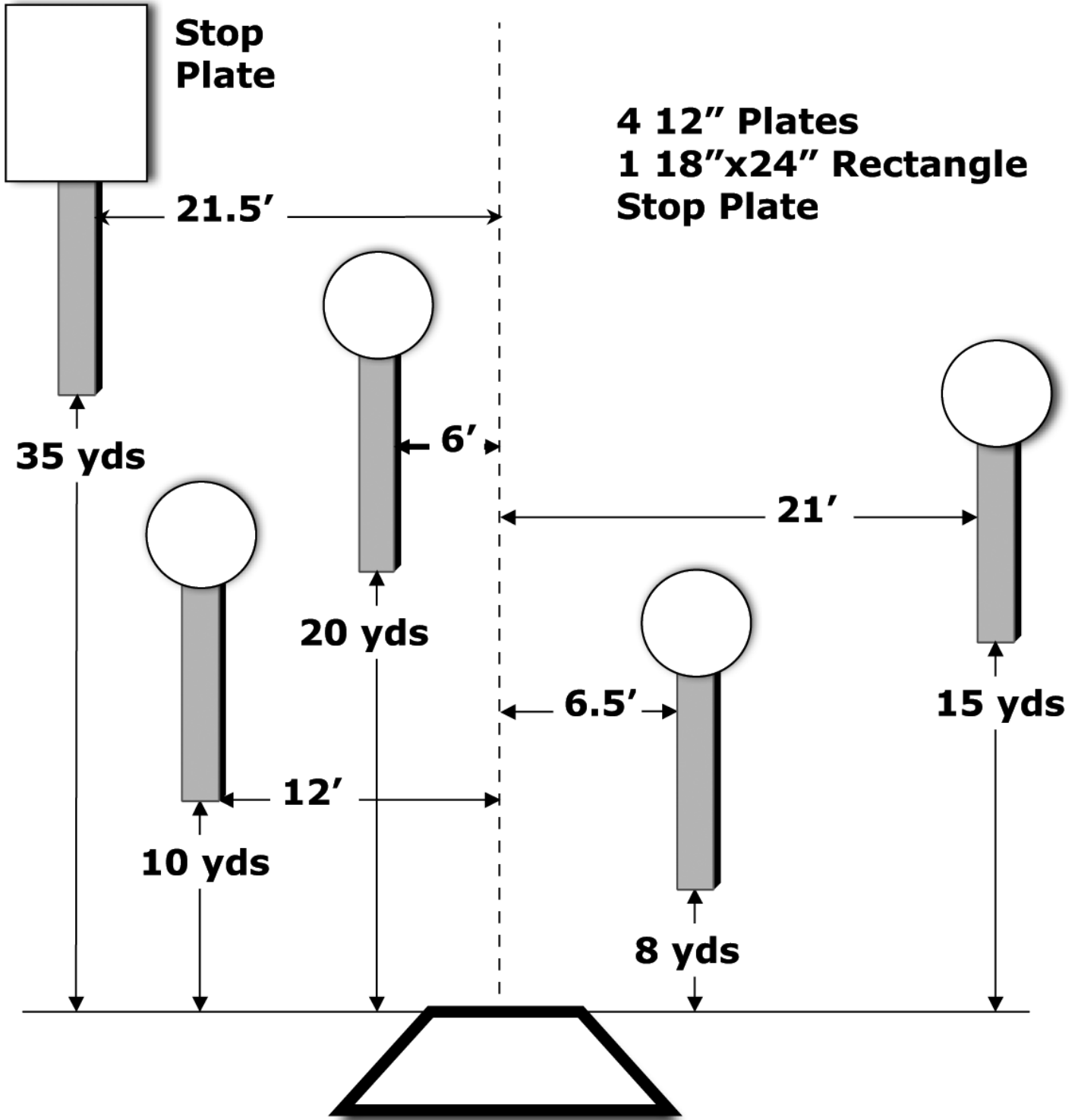

SPEED OPTION